

ALCOHOL DETECTOR AND ENGINE LOCKING SYSTEM USING ARDUINO UNO AND MQ3 SENSOR

A PROJECT REPORT

SUBMITTED BY

KAVIYA S	111621104074
MONIKA G	111621104090
HANISHA M	111621104084
HARINI SREE S	111621104049

partial fulfilment for the award of the degree of

BACHELOR OF ENGINEERING

IN

ELECTRONICS AND COMMUNICATION ENGINEERING

R.M.K COLLEGE OF ENGINEERING AND TECHNOLOGY
PUDUVOYAL

APRIL 2023

TABLE OF CONTENTS

S.NO	CONTENT	PAGE NO
1.	ABSTRACT	4
2.	INTRODUCTION	6
3.	WORKING PRINCIPLE	7
4.	CIRCUIT DIAGRAM	8
5.	EQUIPMENTS REQUIRED	9
6.	PROGRAM	18
7.	ADVANTAGES	21
8.	LIMITATIONS	22
9.	FUTURE DEVELOPMENTS	23
10.	CONCLUSION	26
11.	REFERENCE	27

1. ABSTRACT

"Prevention is better than cure." This quote perfectly summarizes the purpose of the alcohol engine lock system with MQ3 sensor. This system is a proactive approach to prevent accidents caused by drunk driving, rather than waiting for an accident to happen and then trying to remedy the situation. The use of technology in preventing drunk driving has proven to be an effective tool in saving lives and preventing injuries on the road.

The implementation of the alcohol engine lock system with MQ3 sensor has been met with some resistance from those who feel that it infringes on their personal freedoms. However, it is important to remember that the safety of all road users should be a top priority. The use of the system can help reduce the number of accidents caused by drunk driving and ultimately save lives. It is a small price to pay for the safety of all road users.

In conclusion, the alcohol engine lock system with MQ3 sensor is a critical technology in preventing alcohol-related accidents on the road. This system has been successfully implemented in various countries around the world and has proven to be an effective tool in reducing the number of accidents

caused by drunk driving. As the famous saying goes, "Safety doesn't happen by accident." It is up to all of us to take proactive measures to ensure the safety of ourselves and others on the road.

2.INTRODUCTION

The alcohol detector and engine locking system is designed to prevent drunk driving, which is a major cause of accidents and fatalities on the road. It has been implemented in various forms in different countries, and in some places, it is mandatory for certain drivers, such as those with prior DUI convictions or commercial drivers. Drunk driving is a serious problem in many countries around the world. According to the National Highway Traffic Safety Administration (NHTSA), in 2019, 10, 142 people died in alcohol-impaired crashes in the United States alone. To address this issue, various technologies have been developed to prevent drunk driving, including the alcohol detector and engine locking system. This report will discuss the working principles, advantages, and limitations of this technology.

2. WORKING PRINCIPLE

The alcohol detector and engine locking system is a safety feature that is designed to prevent drivers from operating their vehicles if their blood alcohol content (BAC) level is above a certain limit. The system typically consists of a breathalyzer device that measures the driver's BAC level and a computer system that controls the engine and ignition.

When a driver enters the vehicle, they are required to blow into the breathalyzer device. The device measures the alcohol content in their breath and calculates their BAC level. If their BAC level is above the set limit (usually 0.08% in the United States), the engine will not start. If the driver attempts to start the engine multiple times and continues to have a high BAC level, the system may trigger an alarm or notify law enforcement.

4.CIRCUIT DIAGRAM

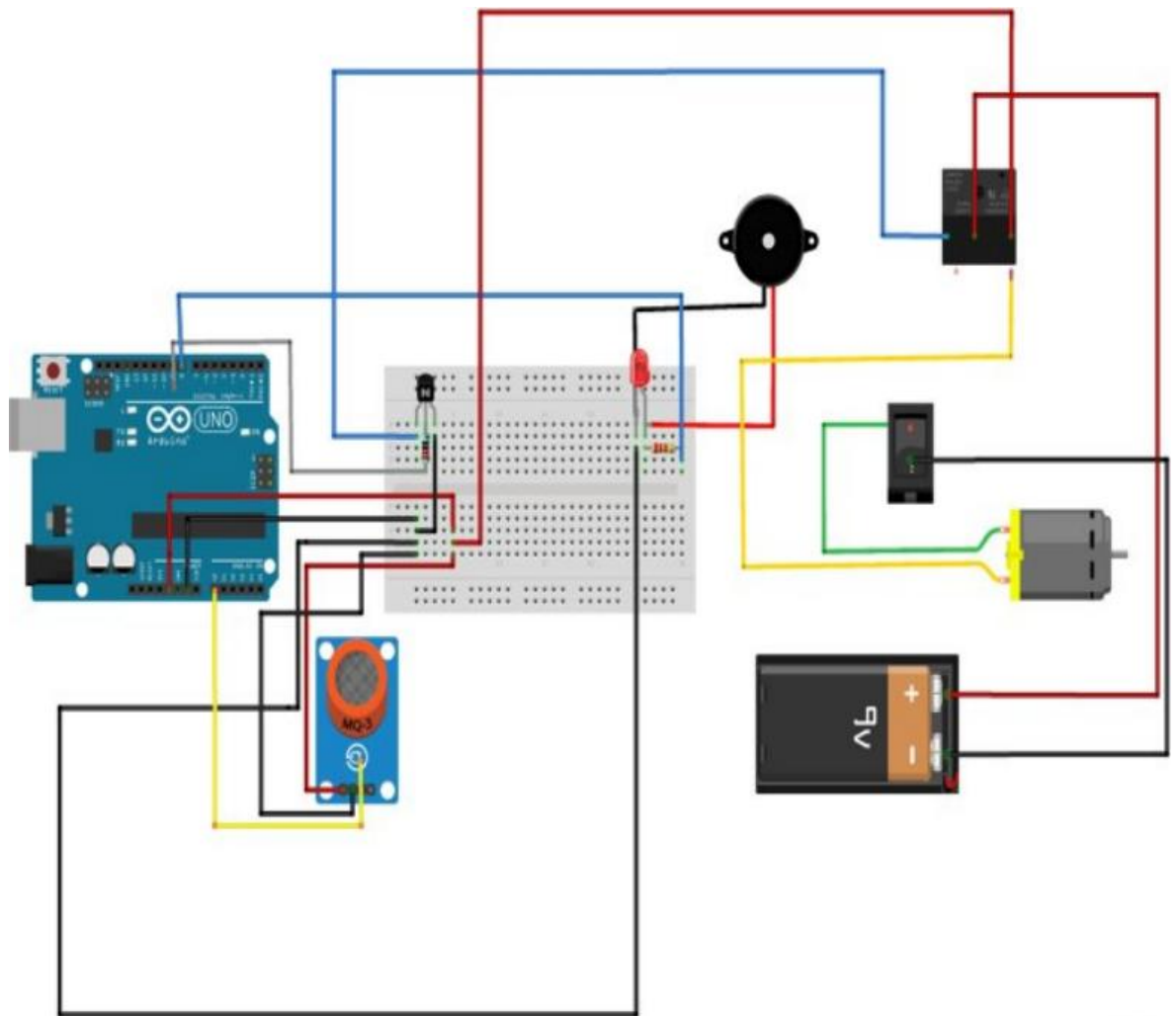

fritzing

5. EQUIPMENTS REQUIRED

1. ARDUINO UNO

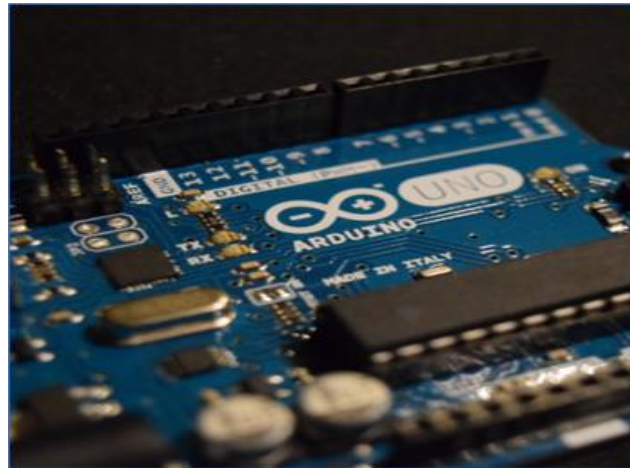

The Atmega-328P-based Arduino Uno is a development board for microcontrollers.

The Arduino produces a variety of different functions, including microcontroller units, computer circuit units, and primarily tiny computers that can run simple software programmes. These units are sufficiently low-powered and can be steam powered for years by various batteries, but they are prepared to measure information much more quickly than a person's brain can process or suppose.

3. MQ 3 SENSOR

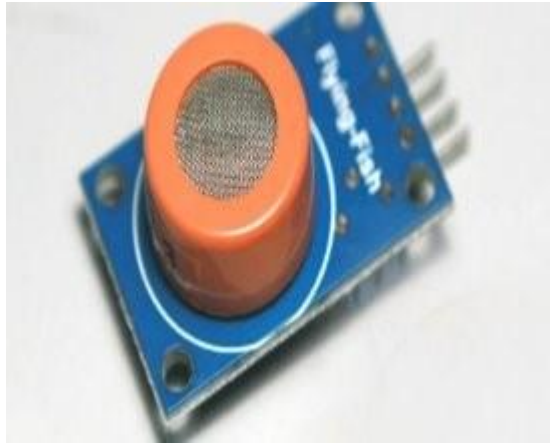

Tin Dioxide (SnO_2) is a thin layer that makes up the MQ-3 sensor. It is sorted out in a way that gives alcohol great affectability and benzene low affectivity. Because of its instantaneous driving circuit, it offers a dynamic response, superior quality, and a longer lifespan. It has a distinct interface style. Port pins 1, 2, and 3 on the sensor tend to the yield, GND, and VCC separately.

3.BO MOTOR



Bo motor (Battery Operated) lightweight DC geared motor which gives good torque and rpm at lower voltages. Here you can get BO motor with varying rated speed. This motor can run at approximately 200 rpm when driven by a single Li-Ion cell. Great for battery operated lightweight robots.

The motor has the ability to operate with minimum or no lubrication, due to inherent lubricity. The motor is ideal for DIY enthusiasts. This motor set is inexpensive, small, easy to install, and ideally suited for use in a mobile robot car. They are commonly used in our 2WD platforms.

4.RELAY

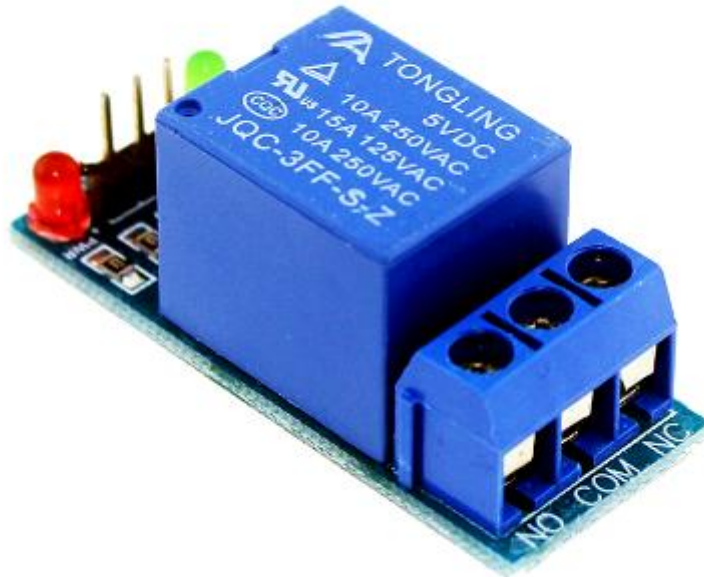

The purpose of the relay in the alcohol engine lock system with MQ3 sensor is to provide a safe, reliable, and fail-safe method of controlling the high voltage and current required to activate the engine lock mechanism. The positive relay provides isolation and protects the microcontroller and other electronic components from voltage spikes and other electrical disturbances, ensuring the safety and reliability of the system.

4. BC 547 TRANSISTOR

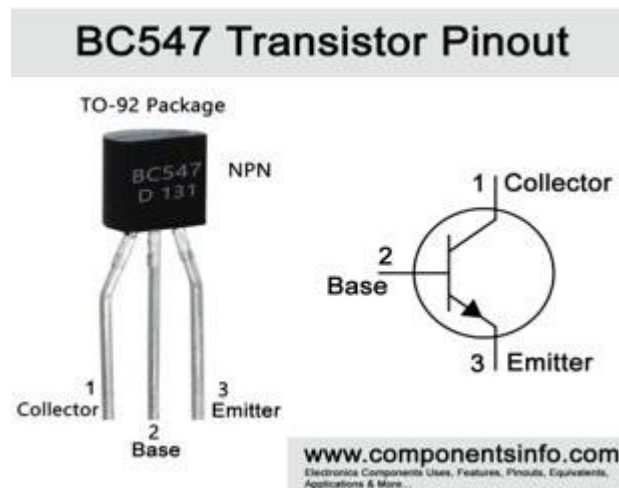

BC547 is usually used for current amplifier, quick switching and pulse-width modulation (PWM).

Therefore, if you need to control the speed of a motor or actuator in some of your projects, you can simply use this transistor to achieve it. In addition, it can also be used as a switch that you can easily switch on or off a DC device with this transistor.

6. 9V BATTERY



The 9V battery is typically connected to the power input of the microcontroller and other electronic components, providing a steady stream of power to keep the system running. It is important to use a battery with sufficient voltage and capacity to ensure that the system operates reliably and consistently.

The use of a 9V battery in the alcohol engine lock system with MQ3 sensor has several advantages. Firstly, the 9V battery is compact and portable, making it easy to install and transport. Secondly, the 9V battery has a long shelf life, which means that it can be stored for extended periods without losing its charge. Thirdly, the 9V battery provides a stable and reliable source of power, ensuring that the system operates correctly and consistently.

7.LED



In an alcohol engine lock system with MQ3 sensor, an LED (Light Emitting Diode) can be used to provide visual feedback to the driver and other passengers. The purpose of the LED in this system is to indicate the status of the system and whether the engine is locked or unlocked.

8. BUZZER



The purpose of the buzzer in the alcohol engine lock system with MQ3 sensor is to provide audio feedback to the driver and other passengers, indicating the status of the system and whether the engine is locked or unlocked. The buzzer provides an important safety feature to prevent drunk driving accidents and protect public safety , and can also be used to provide other types of audio feedback for maintenance and troubleshooting purposes.

9. RESISTOR

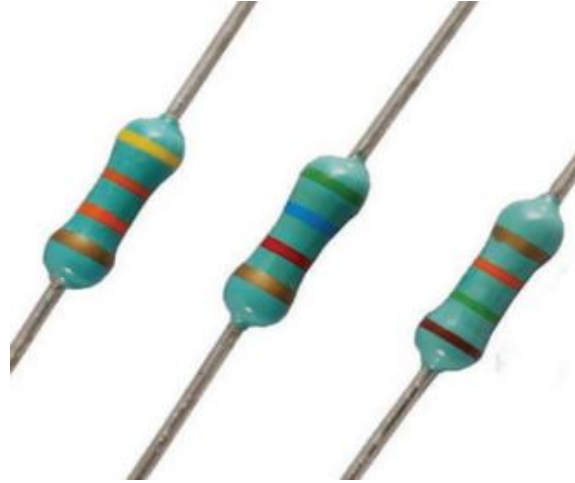

The purpose of the resistor in the alcohol engine lock system with MQ3 sensor is to limit the flow of electrical current and protect the other components in the circuit. Resistors are used to ensure that the LED and other components operate within their safe operating range, and prevent them from being damaged by excessive current. They can also be used to protect other components in the circuit, making them an important component in the system.

10. BREAD BOARD

6.PROGRAM

```
#define sensorDigital A0
#define Motor 7
#define buzzer 8
void setup()
{
  pinMode(sensorDigital, INPUT);
  pinMode(Motor, OUTPUT);
  pinMode(buzzer, OUTPUT);
  Serial.begin(9600);
}
void loop()
{
  int t=digitalRead(Motor);
  Serial.println(t);
  int digital = analogRead(sensorDigital);
  Serial.print("t");
  Serial.print("Digital value :");
  Serial.println(digital);
  if (digital > 700) {
    digitalWrite(Motor, LOW );
    digitalWrite(buzzer, HIGH);
  }
  else
  {
    digitalWrite(Motor, HIGH);
    digitalWrite(buzzer, LOW); }
}
```

OUTPUT WHEN ALCHOL IS DETECTED

```
-  
tDigital value :782  
0  
tDigital value :775  
0  
tDigital value :780  
0  
tDigital value :779  
0  
tDigital value :779  
0  
tDigital value :778  
0  
tDigital value :770
```

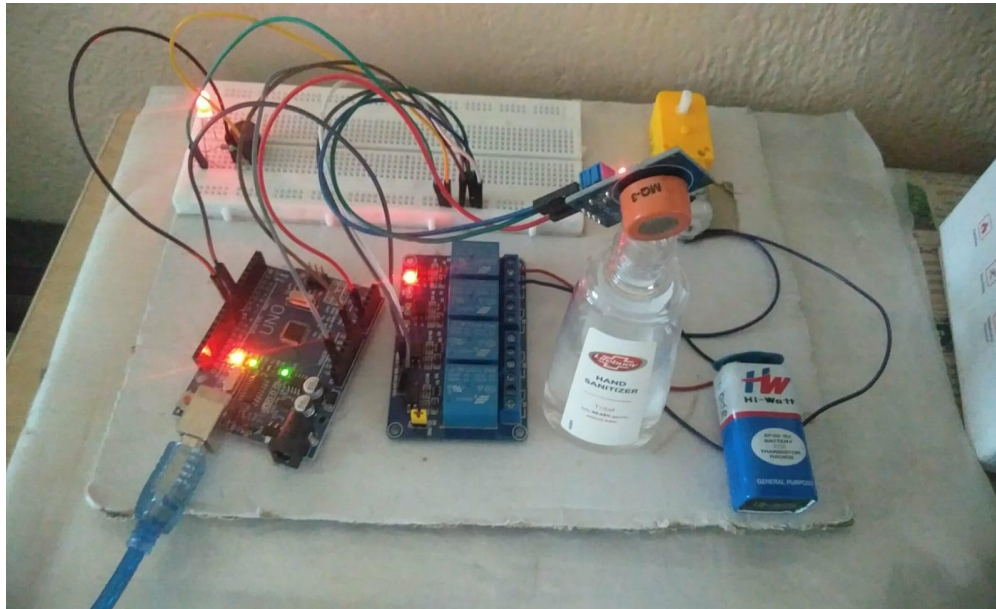

7.ADVANTAGES

The alcohol detector and engine locking system has several advantages in preventing drunk driving. First, it can accurately measure a driver's BAC level and prevent them from operating the vehicle if their level is above the legal limit. This reduces the risk of accidents caused by impaired driving.

Second, the system can help to deter drunk driving by providing a visual reminder of the consequences of drinking and driving. Drivers are aware that they will not be able to operate their vehicles if they have consumed alcohol, which can discourage them from drinking and driving.

Third, the alcohol detector and engine locking system can be used as a probationary tool for individuals who have been convicted of DUI (Driving Under the Influence) or DWI (Driving While Intoxicated). The system can be installed in their vehicles as a condition of their probation, which ensures that they do not violate the terms of their probation by driving under the influence of alcohol.

8. LIMITATIONS

Despite its advantages, the alcohol detector and engine locking system also has some limitations. One limitation is that the system is not foolproof. Drivers may attempt to bypass the system by having a sober passenger blow into the breathalyzer device or by tampering with the device.

Second, the cost of installing the system in all vehicles may be prohibitive. While the cost of the technology has decreased in recent years, it may still be too expensive for many drivers or manufacturers.

Third, the system may be seen as an invasion of privacy by some drivers. Some drivers may be uncomfortable with the idea of having their BAC levels monitored every time they enter their vehicle.

9.FUTURE DEVELOPMENTS

The development of alcohol detectors and engine locking systems is an ongoing process, and there are several potential future developments that could enhance their effectiveness and functionality. Here are some of the possibilities:

Integration with biometric sensors: Future alcohol detectors and engine locking systems may incorporate biometric sensors to detect specific physical characteristics that indicate impairment, such as changes in pupil size, body temperature, or heart rate.

Real-time monitoring and reporting: Advanced alcohol detectors and engine locking systems may be capable of transmitting data in real-time to law enforcement agencies or other relevant parties, enabling immediate action to be taken if a driver is found to be impaired.

Improved accuracy: New sensor technologies may be developed that can detect alcohol at lower levels or more accurately differentiate between alcohol and other substances, such as mouthwash or hand sanitizer.

Artificial intelligence (AI) integration: Future systems may incorporate AI algorithms to analyze data from multiple sources, including biometric sensors, GPS, and other vehicle sensors, to better detect impairment and prevent false positives.

Wireless connectivity: Alcohol detectors and engine locking systems may be equipped with wireless connectivity, allowing them to communicate with other vehicle systems or with external devices, such as smartphones or wearable devices.

User customization: Advanced systems may allow users to customize their settings based on their individual needs or preferences, such as setting a different threshold for impairment or disabling the engine lock feature under certain circumstances.

Overall, the future of alcohol detectors and engine locking systems is likely to involve a combination of new sensor technologies, advanced data analytics, and improved user interfaces, all aimed at improving their accuracy, effectiveness, and ease of use.

10.CONCLUSION

In conclusion, the alcohol detector and engine locking system is an important safety feature that can potentially save lives and prevent accidents. It accurately measures a driver's BAC level and prevents them from operating their vehicle if their level is above the legal limit. However, the system also has limitations, such as the possibility of drivers attempting to bypass it and the cost of installation. Overall, the alcohol detector and engine locking system is a valuable tool in preventing drunk driving, but it is not a substitute for responsible driving behavior and public education campaigns about the dangers of drunk driving.

11.REFERENCE

https://drive.google.com/drive/folders/1FDvhYRaBU5W3WNBTQXJ1XIBY1GwfoeZw?usp=share_link

SK.Singh and A.kumar,"Alcohol Detection System for Drunk Drivers," International Journal of Innovative Research in Science,Engineering and Technology,vol-4,pp.11-14,2015.

R.K.Gupta and A.K.Sharma,"Design and Development of Alcohol Detection System for Vehicle Safety," International Journal of Advanced Research in Computer Science and Software Engineering ,vol4,no-8,oo.1027-1030,2014.